

ENCELIUM PHASE CUT DIMMER MODULE (PCDM)

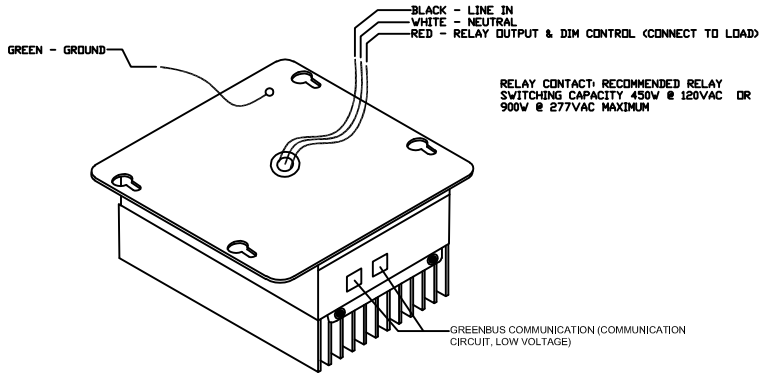

ENCELIUM PHASE CUT DIMMING MODULE (PCDM) - WIRE TABLE

BLACK	LINE (IN)
WHITE	NEUTRAL
RED	RELAY OUTPUT & DIM CONTROL (CONNECT TO LOAD)

PHASE CUT DIMMING MODULE

EN-PCDM-GB2

ENCELIUM PHASE CUT DIMMER MODULE (PCDM)

MOUNTING DETAIL - WCM

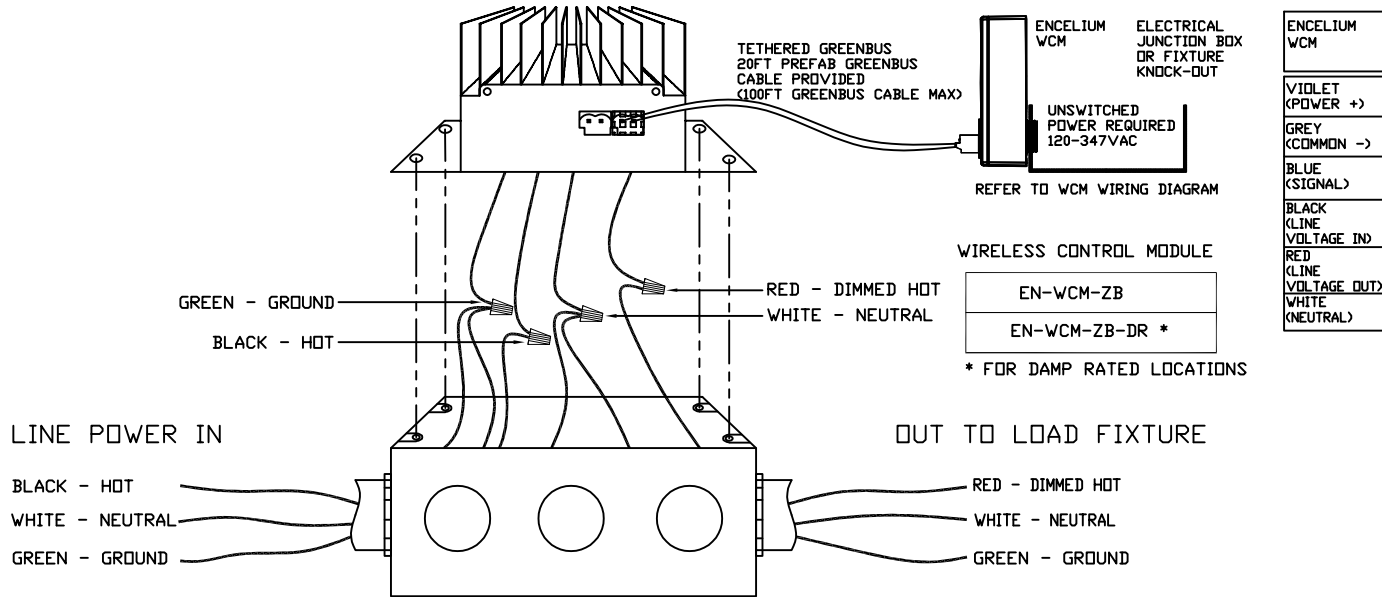

NOTES:

- FOR EASE OF INSTALLATION ENCELIUM GREENBUS USES PROPRIETARY CONNECTORS AND JACKS ONLY.
- ENCELIUM GREENBUS IS A PROPRIETARY STANDARD. CONNECT TO ENCELIUM ENERGY MANAGEMENT SYSTEM ONLY. DO NOT CONNECT TO OTHER CIRCUITS.
- WIRE UNIT IN ACCORDANCE WITH ALL APPLICABLE ELECTRICAL AND BUILDING CODES.
- USE OF ELECTRICAL JUNCTION BOX REQUIRED.
- REFER TO ENCELIUM PCDM INSTALLATION AND SERVICE MANUAL BEFORE INSTALLING OR SERVICING MODULE.
- FOR COMPATIBILITY WITH OTHER CONFIGURATIONS ON ENCELIUM PRODUCTS CONTACT YOUR REPRESENTATIVE.
- DIMMING LENGTH 50FT MAX FROM PCDM

REV	DESCRIPTION/CHANGE	DATE
 www.encelium.com		
TITLE <i>PHASE CUT DIMMING MODULE (PCDM)</i>		
SCALE <i>NTS</i>	PROJ NO.	
DRAWN <i>S.PANERI</i>	DWG. NO. <i>EN-ZB-006-R0-PCDM-WCM</i>	SIZE <i>A</i>
DATE <i>03-MAY-21</i>	FILE NAME <i>PHASE CUT DIMMER</i>	