

WPBC

Wireless Push Button Coupler

Date: _____

Quantity: _____

Company: _____

Project: _____



The Encelium Wireless Push Button Coupler (WPBC) enables convenient control of light levels and works with the Encelium Light Management System.

The WPBC is a binary input device for installation in flush-mounted boxes. The device is powered by a mains connection and an integral part of the Encelium System.

The WPBC has 4 input channels for potential-free contacts. Either switches or push buttons can be connected. Each button (input) on the WPBC is field configurable to suit the desired control scheme in the installed space.

This includes commands such as:

- Turn On and Turn Off
- Dim Up and Dim Down
- Recall Scene
- Toggle On/Off
- Changing and recall color temperature

Key Features & Benefits

- Active Zigbee Mesh device (repeater function)
- Mains powered (no batteries)
- Up to 4 buttons connected and configurable
- Simple On/Off or multi-scene control
- Easy and versatile installation and wiring with color coded wires
- >50,000 h lifetime at $t_a = 60^\circ\text{C}$ (140°F)
- Compatible with standard recessed boxes
- Works with:
 - Encelium X
 - Encelium Extend

Specifications

SENSING AND CONTROL

Typical Connectivity Range

- 15 m (49 ft), depending on mounting environment

Frequency Range

- 2,400 – 2,483.5 MHz

Radiated Power

- 8 dBm

Communication Standard

- Zigbee

ELECTRICAL

Nominal Supply Voltage

- 230 V, 50/60 Hz

Nominal Power Consumption

- 0.2 – 1 W

Galvanic Insulation Push Button Interface to Mains

- Basic Insulation (use wires suitable for mains voltage)

Number of Inputs

- 4

ENVIRONMENTAL

Ambient Temperature Range

- -20° – 60°C (-4° – 140°F)

Maximum Allowed Case Temperature

- 70°C (158°F) measured on t_c point

Maximum Case Temperature in Fault Condition

- 110°C (230°F)

Storage Temperature Range

- -25° – 85°C (-13° – 185°F)

Relative Humidity

- 5% – 85%, non-condensing

Expected Lifetime

- 50,000 hours at $t_a = 60^\circ\text{C}$ (140°F)

PHYSICAL

Dimensions (H x W x D)

- 49 x 48 X 22 mm (1.9 x 1.8 X 0.87 inch)

Weight

- 233 g (8.2 oz)

Cable Length

- 280 mm (11 inch), extendable to 3 m (10 ft) maximum per channel

Wire Diameter

- 0.55 mm (0.02 inch), cross section 0.22 mm² (0.008 inch²)

WARRANTY

- For warranty details, refer to the full warranty documentation at www.encelium.com

CERTIFICATIONS & SAFETY

Approbations

- CE
- FCC

Environmental Suitability

- IP20, Indoor



Ordering Information

EAN10	EAN40	Description	Pieces/Box
4052899591561	4052899591578	Wireless Push Button Coupler	60

Dimensions

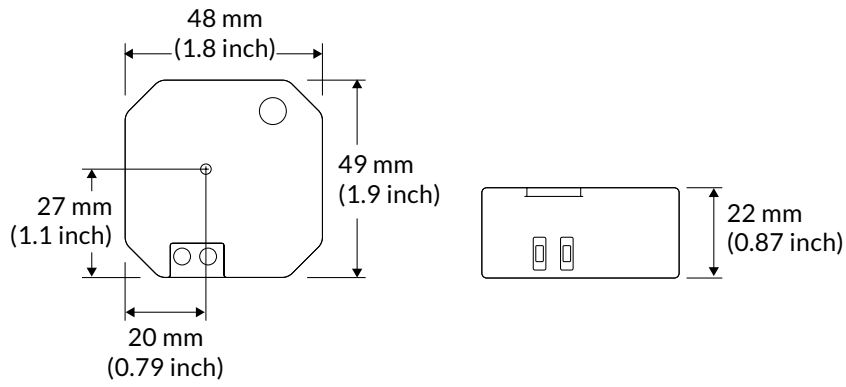

Wiring Diagram

