

# Wired Manager – GreenBus

## Encelium X Wired Manager

Date: \_\_\_\_\_

Quantity: \_\_\_\_\_

Company: \_\_\_\_\_

Project: \_\_\_\_\_

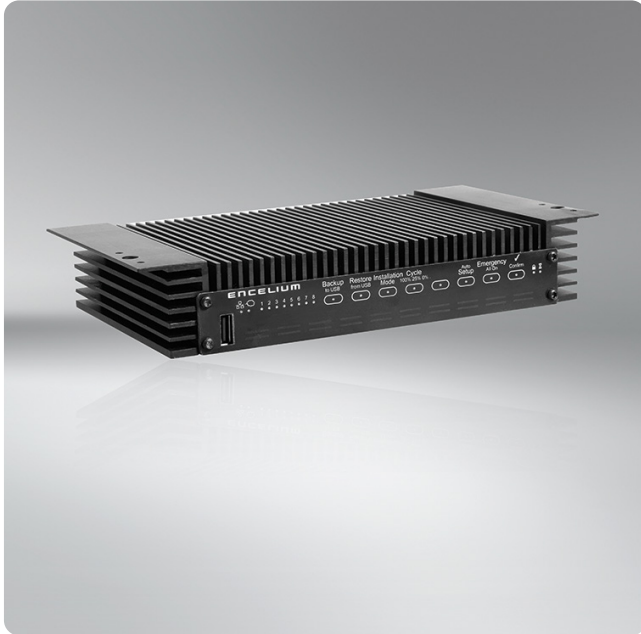

The **Wired Manager – GreenBus** is a rack or wall-mounted control device that collects, processes, and distributes lighting control information to Encelium X control modules, wall controllers, and other devices over the GreenBus network.

Each Wired Manager – GreenBus features eight GreenBus communication channels and typically controls 100 devices per channel – up to a total of 800 devices total per manager. Additional wired managers can connect and scale a system to a maximum of 30,000 devices.

The Wired Manager – GreenBus is the central intelligence point in the system. It collects signal information from photosensors (light levels), occupancy sensors (occupancy status), and wall-mounted lighting controllers. It then determines appropriate brightness levels or ON/OFF status for each luminaire and zone. Photosensors do not directly control light levels but rather are connected to the GreenBus network and provide light level information to the Manager. The Wired Manager – GreenBus then determines what action to take based on the status signals from the sensors.

### Works with

- Encelium X
  - ▶ GreenBus Wired



### Key Features & Benefits

- Incredible flexibility of design – provides scaling system for applications of any size
- Can be combined with the Encelium Wireless Manager for a combined wired and wireless hybrid solution
- Controls up to 800 wired devices per manager
- Sleek design for seamless wall or rack installation. 483 mm (19 inches) rackmount requires a 1U slot with an optional 4U wall-mounted rack

# ENCELIUM

# Specifications

---

## SENSING AND CONTROL

### Control

- GreenBus Communication

### Control Options

- 8-Channel GreenBus Ports, 2.5 VDC, Class II
- Controls 100 nodes per channel – up to a total of 800 nodes per Wired Manager – GreenBus

### USB<sup>1</sup> LAN Access

- 2.0 Port to restore or back up database from USB drive
- 1TU2.ET100 required for G4 (sold separately)

### Configuration

- Stored in non-volatile flash memory

### Communication Status

- LED, 8-channel<sup>2</sup>

## ELECTRICAL

### External Power Supply<sup>3</sup>

- 100 to 240 VAC, 50/60 Hz, 1.8A

### Circuit

- Normal non-emergency circuit only<sup>4</sup>

## ENVIRONMENTAL

### Operating Temperature

- 0° to 40°C (32° to 104°F)

## PHYSICAL

### Dimensions (H x W x D)

- 39.4 x 228.6 X 119.6 mm (1.55 x 9 X 4.7 inches)

### Weight

- 1.02 kg (36 oz)

### Housing Color

- Black

### Housing Material

- Steel

### Mounting Options

- 1U Rack Mount, 482.6 mm (19 inches)
- Individual Wall Mount
- 4U Wall Mounted Rack (Optional)

## WARRANTY

- For warranty details, refer to the full warranty documentation at [encelium.com](http://encelium.com)

## CERTIFICATIONS & SAFETY

### Approbations

- UL/cUL Listed, Energy Management Equipment (UL 916)
- FCC Part 15/ICES-003, Class A

### Complies with Electromagnetic Compatibility (EMC) Standards:

- EN 61000-4-2
- EN 61000-4-4
- EN 61000-4-5

### Environmental Suitability

- Pollution Degree 2 or greater



#### Footnotes:

- <sup>1</sup> Should only be used with the instruction from Encelium personnel.
- <sup>2</sup> LED located on front of unit.
- <sup>3</sup> Power supply provided with Wired Manager – GreenBus.
- <sup>4</sup> Do not connect to UPS or emergency power.
- <sup>5</sup> Install in accordance with all applicable national and local electrical and building codes.

## Power Supply Specifications

---

### ELECTRICAL

#### Power Supply

- 100 to 240 VAC, 50/60 Hz, 1.8A

### PHYSICAL

#### Dimensions (H x W x L)

- 41 x 83.8 X 170.2 mm (1.6 x 3.3 X 6.7 inches)

#### Weight

- 0.77 kg (27.2 oz)

#### Cord Length

- 1.2 m (4 ft)

## Power Supply Dimensions

---

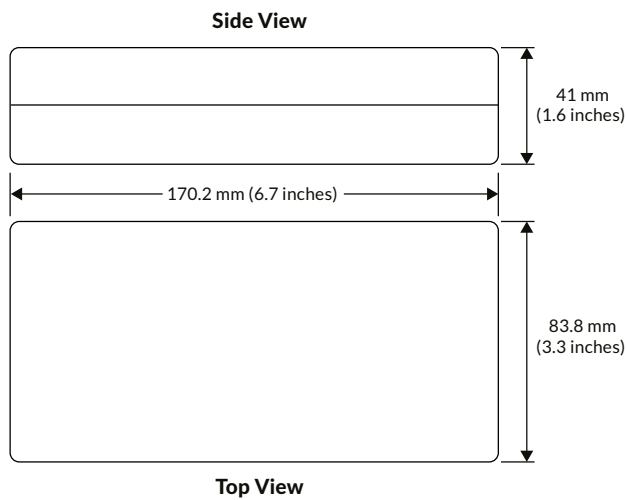

## Ordering Information

Catalog Number	Description	Approbations	Communication Network	System Compatibility
EN-M-GB2-X	Wired Manager – GreenBus <sup>6</sup>	UL	GreenBus	Encelium X
EN-ECU-G4-P3D	Wired Manager – GreenBus <sup>6</sup>	UL	GreenBus	Encelium Extend

<sup>6</sup> Power Supply included with Wired Manager – GreenBus.

## Wired System Overview

GreenBus technology makes wiring fast and error-free, since it's intuitive to install. With Encelium X, you can control DALI devices exclusively or a mixture of GreenBus and DALI. With any Encelium wired design, you get a reliable, on-site lighting control system that can be installed quickly and easily.

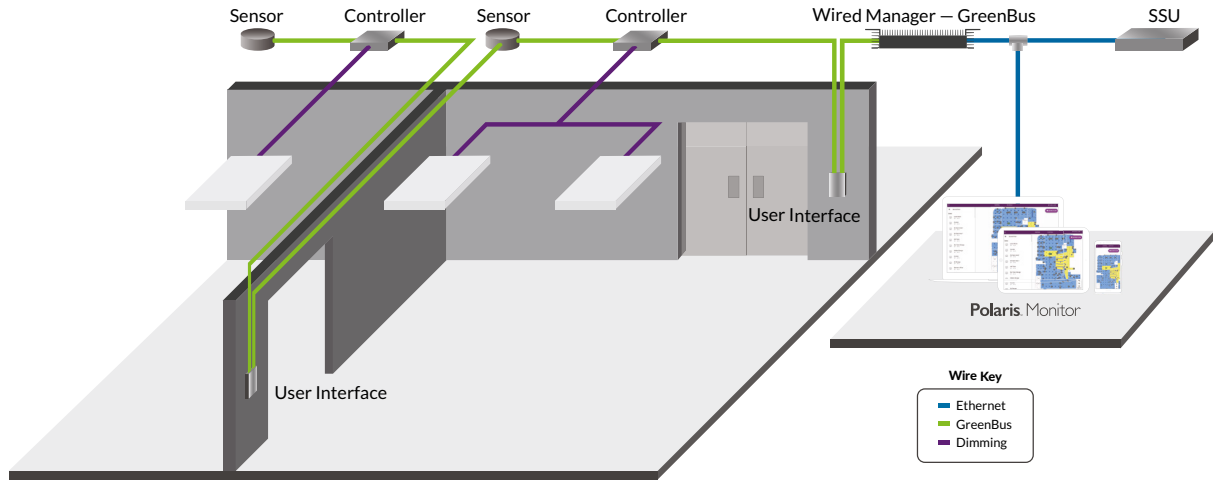

## Wiring Diagram

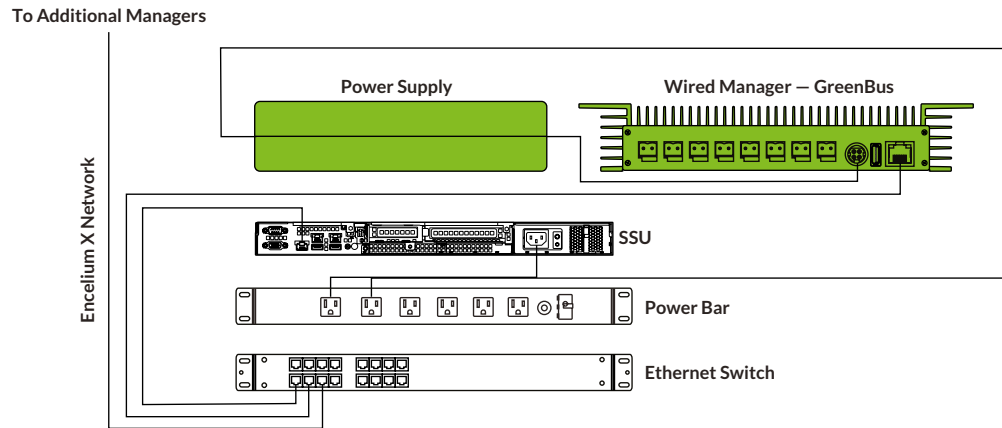

Encelium X Ethernet connections to Wired Manager – GreenBus, System Support Unit, Ethernet Switch, and Tenant LAN.

## Mounting Options

The mechanical construction allows the Wired Manager – GreenBus to be attached to a (19 inches) wide bracket, for simple installation on standard 482.6 mm (19 inches) IT rack (1U width), or optional 4U wall mounted rack. The 482.6 mm (19 inches) wide bracket is provided with the Wired Manager – GreenBus. For individual wall-mount, the mounting ears on the Wired Manager – GreenBus can be used to secure against a vertical surface without needing an external mounting bracket.

### Rack Mount

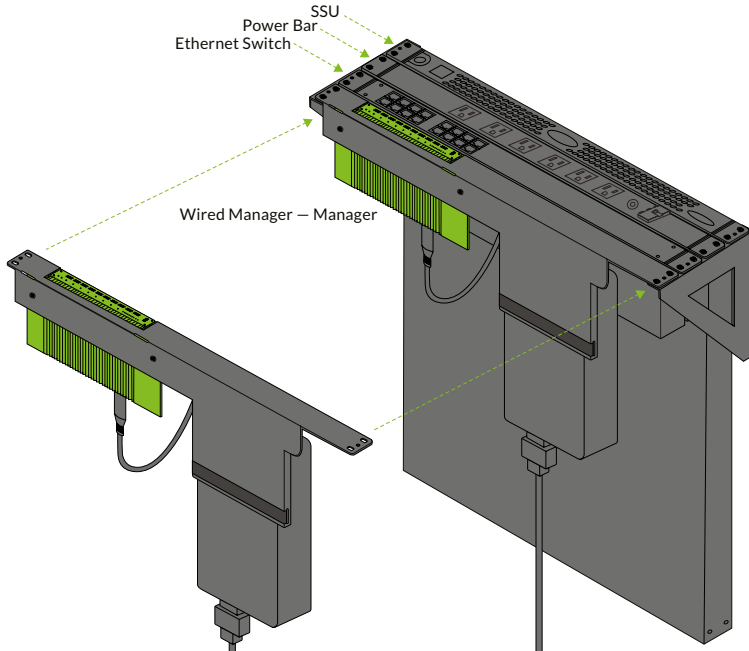

### Wall Mount

