

Wireless Manager

Encelium X Wireless Manager

Date: _____

Quantity: _____

Company: _____

Project: _____



The Encelium X **Wireless Manager** is the central intelligence point in the system for wireless devices. It collects information from photo sensors, occupancy sensors and wallstations to enable multiple lighting control strategies. It then determines appropriate brightness levels or ON/OFF status for each luminaire and zone.

The Wireless Manager communicates via a mesh network. Each Manager must be connected to an Ethernet (PoE) Network Switch using standard Cat-5 or greater Ethernet data cabling. Wireless Managers typically control individual floors and are linked via an Ethernet Network back to the lighting control network.

The Encelium X Wireless Manager is an ioXt Certified Product.

Works with

- Encelium X
 - ▶ Wireless



Key Features & Benefits

- Encelium X Wireless Manager is an **ioXt Certified Product**
- Control up to 100 wireless devices in a space
- Sleek and high aesthetic design with simple mounting for ceilings or walls
- Can be combined with the Encelium Wired Manager for a combined wired and wireless hybrid solution
- Simple connection by Power-over-Ethernet (PoE) with Dual PoE ports for daisy-chaining Wireless Managers

Specifications

SENSING, CONTROL, AND SECURITY

Control

- Wireless Communication

Wireless Range

- 30.5 m (100 ft) line of sight
- 15.2 m (50 ft) through standard walls

Radio

- Frequency Range: 2405-2480 MHz
- Channel Space: 5MHz
- Modulation Type: O-QPSK
- Transmit Power: 13.40dBm EIRP (max)

Security Certification

- ioXt Certified Product

ENVIRONMENTAL

Operating Temperature

- 0° to 40°C (32° to 104°F)

PHYSICAL

Dimensions (H x W x D)

- 117.6 x 71.4 X 19.8 mm (4.6 x 2.81 X 0.78 inches)

Weight

- 110 g (3.9 oz)

Housing Color

- White

Housing Material

- PC/ABS Plastic

Mounting Options

- Ceiling Tile Mount
- Wall Mount

WARRANTY

- For warranty details, refer to the full warranty documentation at encelium.com

CERTIFICATIONS & SAFETY

Approbations

- UL/cUL Listed, Energy Management Equipment (UL 916)
- CE
- FCC Part 15/ICES-003, Class A

Complies with Electromagnetic Compatibility (EMC) Standards:

- EN 61000-4-2
- EN 61000-4-4
- EN 61000-4-5



Dimensions

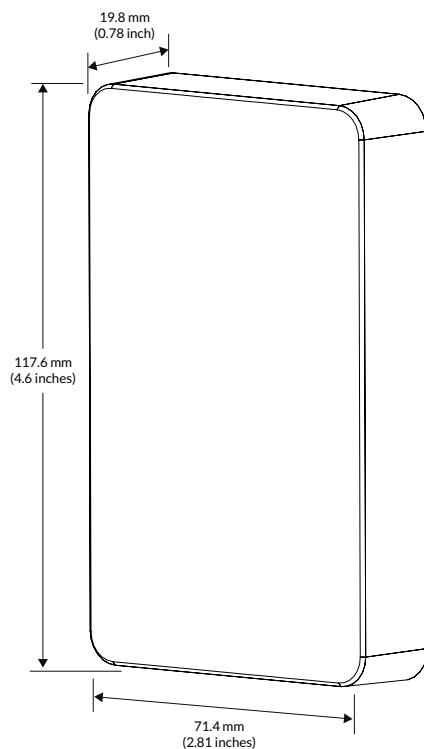

Ordering Information

Catalog Number	Description	Approbation	Communication Network
EN-WM-ZB-X	(Encelium X Wireless Manager	UL and CE	Encelium X
EN-WM-ZB-P3D	Encelium Extend Wireless Manager	UL and CE	Encelium Extend

Wireless System Overview

This illustration shows how each component is easily integrated into the Encelium X Lighting Control System.

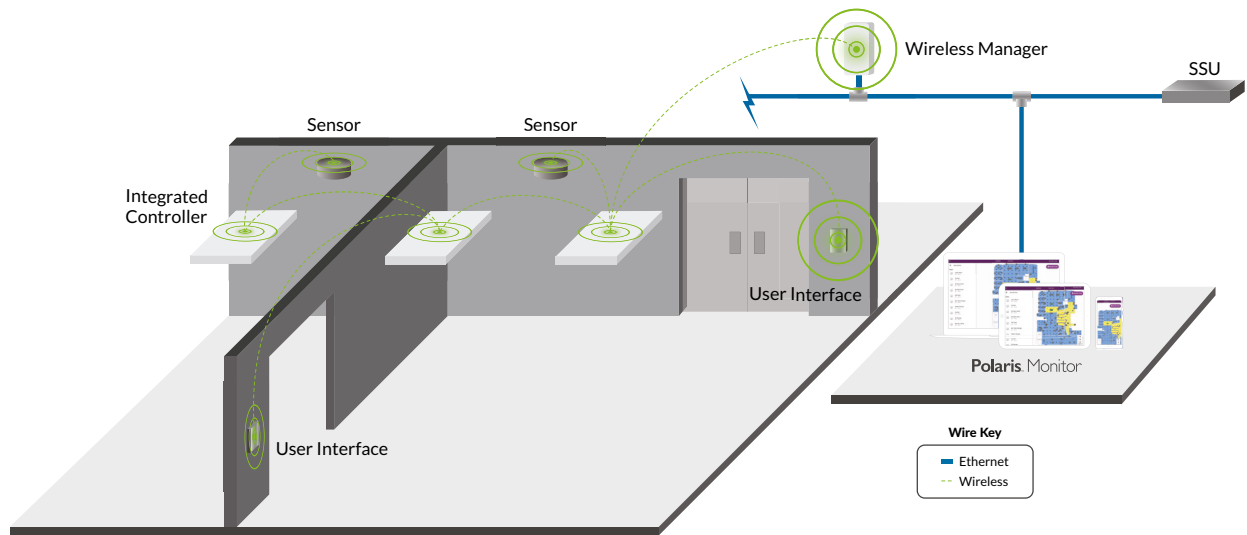

Wiring Diagram

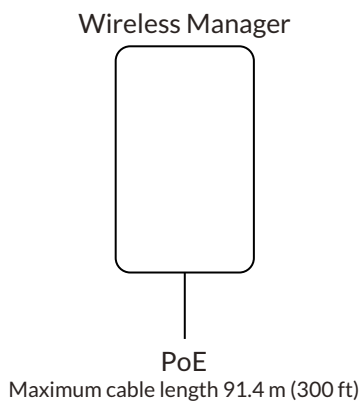

Mounting Options

Ceiling Tile Mount

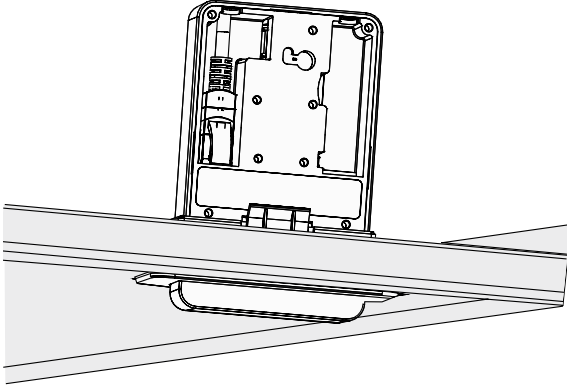

Wall Mount

